

Instructions for the use of the **Link 4 Pallet Rack Lifter (PRL) model 5000**

(How to move your pallet racking using the Link 4 Pallet Rack Lifter)

This process is for a typical rack move and reset. Each project will have variants unique to its location.

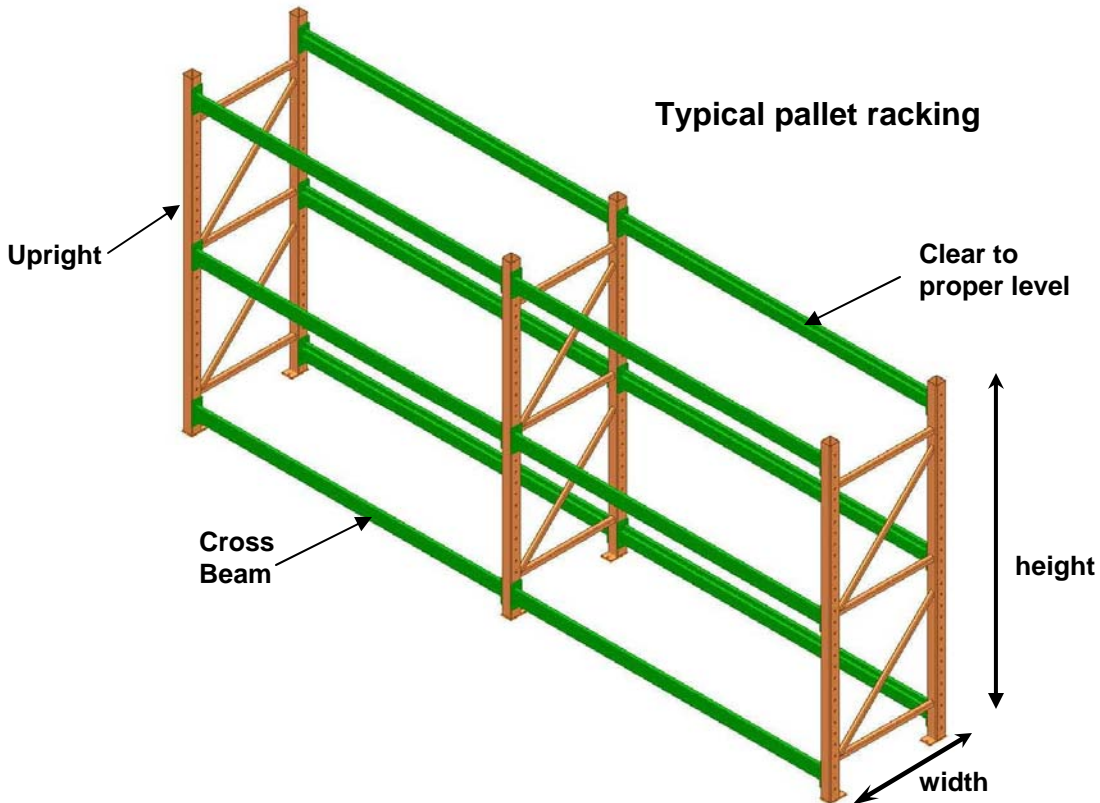

Checklists and to do items:

- A. Verify that the Pallet Rack Lifter cabinet is on site and staged at the move location
- B. Remove all items from the pallet rack shelves that are above the following heights:
 - a. Above the 8 foot level with rack that has a depth of 36 inches
 - b. Above the 10 foot level with rack that has a depth of 42 inches
 - c. Above the 12 foot level with rack that has a depth of 48 inches
 - d. Any items remaining on the pallet racking must not exceed the 5,000 pound capacity per Pallet Rack Lifter
- C. Do a visual scan of all products left on the remaining shelves and verify that no items will be shook loose and fall during the move. If the product looks unstable, remove it or stretch wrap it in place.

- D. Check the immediate area surrounding and above the pallet racks for the following:
 - a. Verify that none of the sprinkler heads penetrate the rack area and that none will interfere with the movement of the rack to the new location.
 - b. Verify that no part of a “fire stop” is attached or will interfere with the movement of the rack.
 - c. Verify that all electrical conduits, plugs and light fixtures are disconnected or out of the pallet rack move zone.
 - d. Verify that no duct work, hangers, etc, penetrate or interfere with the movement of the pallet rack.
 - e. Verify that none of the structural steel or support columns will interfere with the lifting and moving of the pallet rack.

- E. Housekeeping
 - a. It is important that the floor be kept as clean and as free of debris as possible to facilitate the smooth rolling of the moving system.
 - b. Remove any and all objects or articles that would interfere with movement of the castors over the floor. Remember, that something as small as a flat washer caught between the castor wheel and the floor will act as a brake and create an undesirable condition.
 - c. Sweep the entire move area with a soft bristle broom just prior to the move.
 - d. Verify that no inventory or miscellaneous items have been left in the path of the pallet rack move route.

- F. Prepare the pallet rack system for the move
 - a. Remove the nuts and washers from the floor anchors on only the pallet rack that you are going to move at this time. If it is appropriate, drive the concrete anchors flush with the floor, otherwise the racking will need to be raised to a height to clear the anchor stick out.
 - b. If the pallet rack does not have a support beams in each bay, front and back within 6 inch of the floor then one must be installed. This gives the necessary support to link the uprights together for strength and stability. Remember that the Pallet Rack Lifter will be mounted on the upright in the vertical space between 6 inch and 24 inch. This area must be clear of any cross beams, etc.
 - c. Remove all of the tie bars/row spacers from between the rows of racking
 - d. Visually verify that none of the remaining items on the shelves will interfere with other shelving as the rack is lifted and moved.

G. Mounting and Installing the Pallet Rack Lifter/Mover system

- a. Bring the Pallet Rack Lifter cabinet into a convenient area close to the pallet rack that is to be moved. (make sure it is not in the path of the move when you park it)
- b. The cabinet is densely packed and will require a certain procedure to unload the parts safely. There are instructions mounted on the cabinet doors. Please refer to these instructions for the particular configuration that you are using.
- c. After the lifter parts have been unloaded from the cabinet install the outrigger support arms in the half of the units that you will be using on the aisle side of the pallet racking that is to be moved. If you are moving a single row of racking, then you will install outriggers on all of the jacks that you will be using.

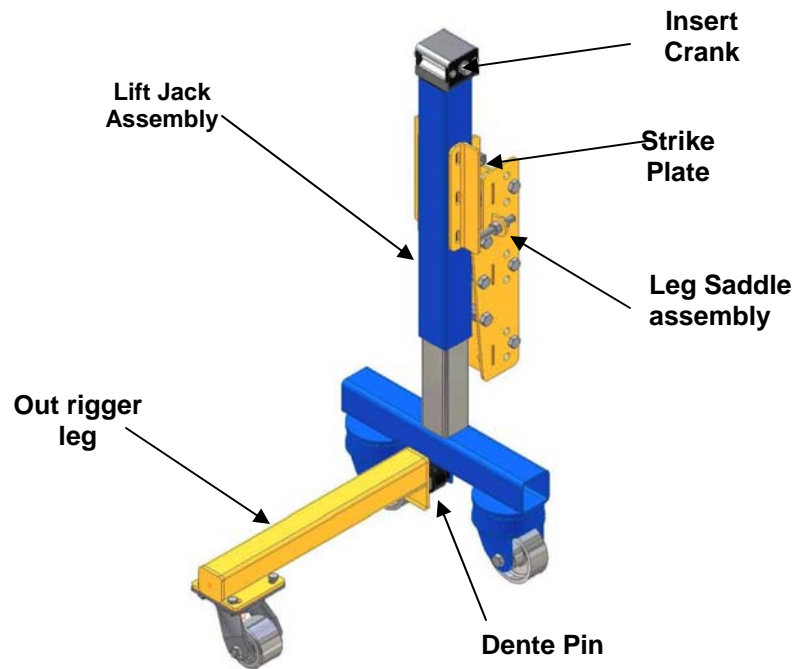

- d. Remove the leg saddle from the half of the lift jack assemblies that will be used between the rows and with the mounting bolts place them to one side for later use. Note: The minimum distance between rows for using the Pallet Rack Lifters is 6 inches.

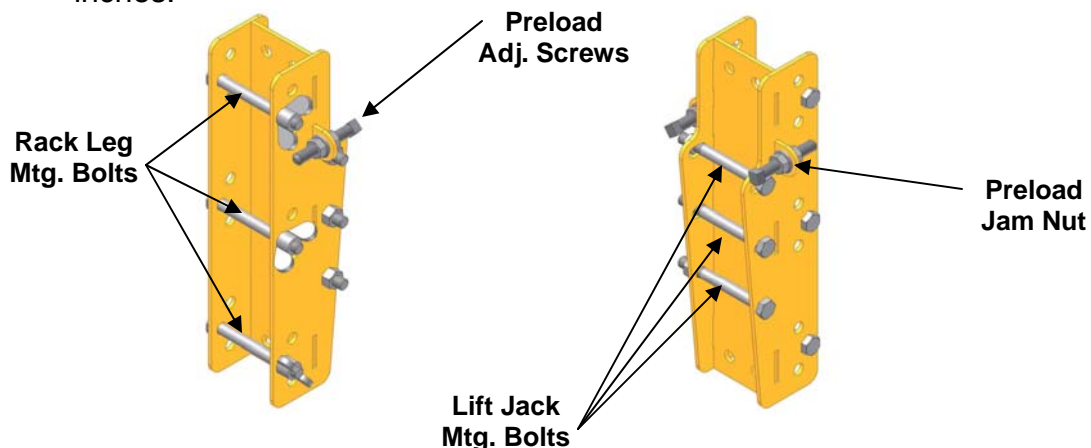

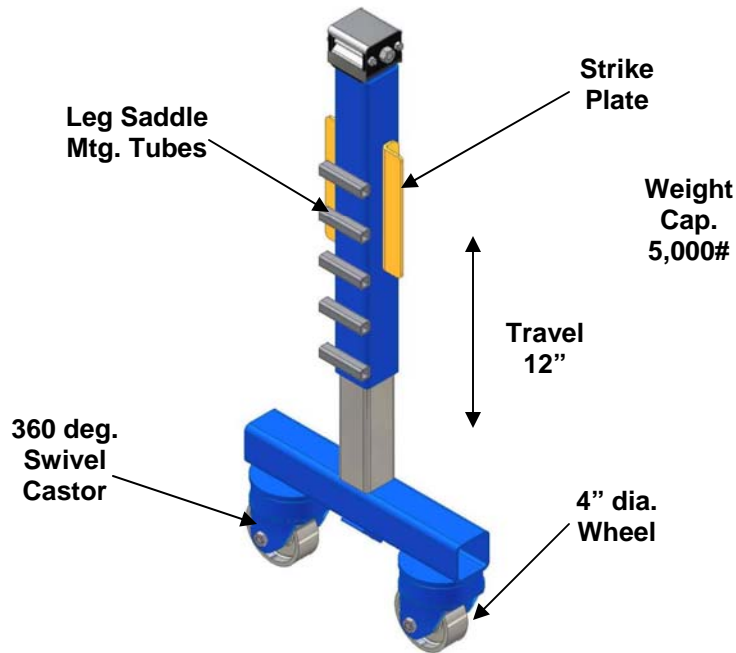

- e. Place the lift jack assembly between the uprights with the mounting tubes facing the upright that will be moved. Center the lift jack assembly on the upright and let it lean between the uprights in order to slide the leg saddle into place.

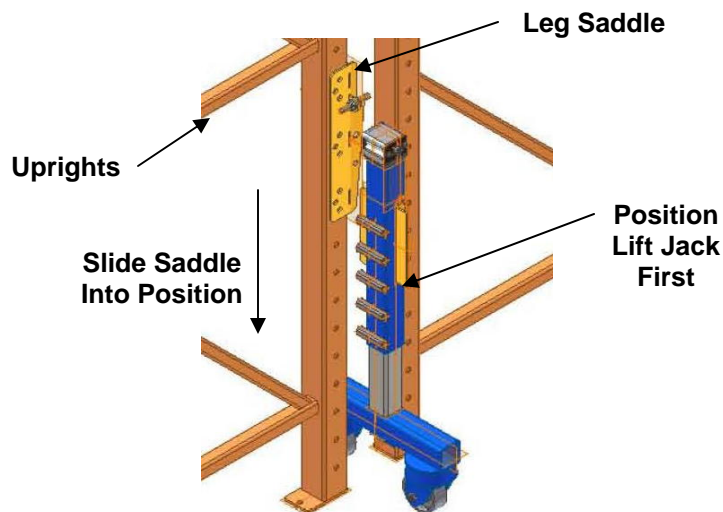

- f. Bring the lift saddle into place by sliding the open face on to the vertical upright just above the lift jack assembly. Then slide the leg saddle down and level with the mounting tubes (on the lift jack assembly). Bring the lift jack assembly into vertical position and insert the mounting bolts through the mounting tubes. All three mounting bolts are required for the capacity rating. Mount the nuts on the mounting bolts, tilt the leg mount back until the preload adjusting screws make contact and use an impact to tighten the nut on all three mounting bolts.
 Note: Usually the preload is set only once for a particular style of uprights. This is done prior to the first move.

- g. Now hand crank the lift jack up or down until the holes in the Leg Saddle and the upright are aligned. Use the largest diameter bolt that will pass through the upright and the Leg Saddle. The normal choice of bolts are:

3/8 x 4 1/2 hex head cap screw grade 5

7/16 x 4 1/2 hex head cap screw grade 5

1/2 x 4 1/2 hex head cap screw grade 5

Use a wing nut and finger tighten. All three bolts must be used in the leg saddle and upright to assure the maximum lift capacity rating.

H. Setting the preload on the Leg Saddle

- The purpose of the preload is to keep the lift jack in a perpendicular position while lifting and carrying the load.
- To set the preload mount a lift jack assembly with the outrigger mounted onto the upright. Install the leg lift bolts and finger tighten the wing nuts.
- With the preload adjusting screw loose, start cranking the jack to put pressure on leg lifting bolts. At this point you should be able to observe the tilting out of vertical on the lift jack. After there is light pressure on the Leg lift bolts, it is time to adjust the preload screws. Place a torpedo level on the side opposite of the leg saddle and start adjusting the preload screws. You should alternate tightening each screw until the lift jack is forced into the perpendicular lift position. At this point, the jamming lock nut should be applied. The preload for this style of racking has been set. At this point the other Leg Saddles will need to be set to the same preload. This is easily accomplished by measuring the distance from the strike plate on the lift jack and preload screw mounting plate of the unit just calibrated and duplicating this measurement on the other units until all units are calibrated.

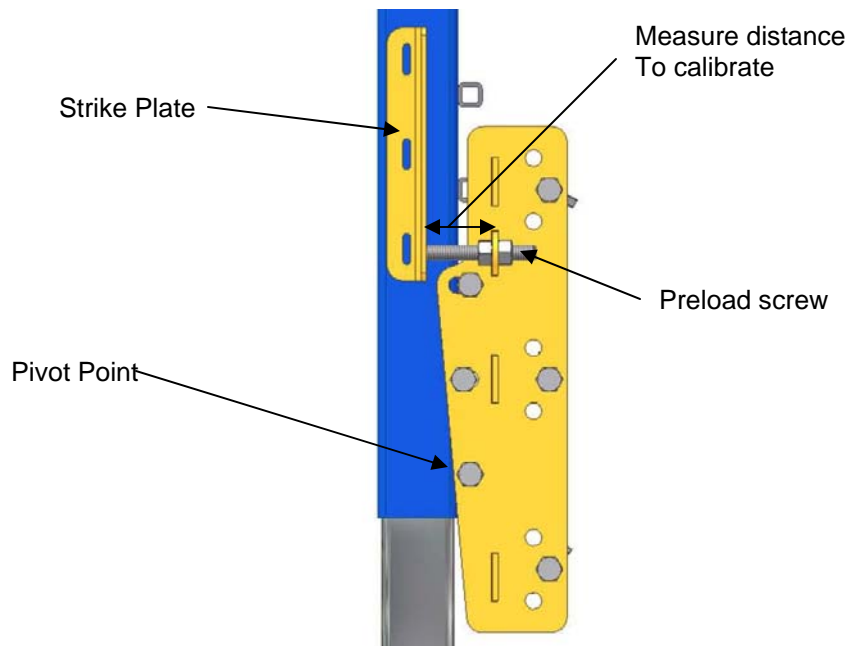

- I. Mounting and installing the Lift Jack assembly on aisle uprights.
 - a. Dolly the Lift Jack assembly with the outrigger and leg saddle already mounted, up to the upright leg and align saddle holes and upright holes, insert required bolts.
 - b. Do this until all uprights have Lift Jack assemblies in place.
 - c. At the time of placing the Lift Jack assemblies, they should all be cranked up to put a fairly uniform pressure on all of Leg Saddles.
 - d. Visually inspect that all Lift Jack assemblies have been correctly mounted to the uprights. Make sure all fasteners are in place and every unit is ready to lift the racking.

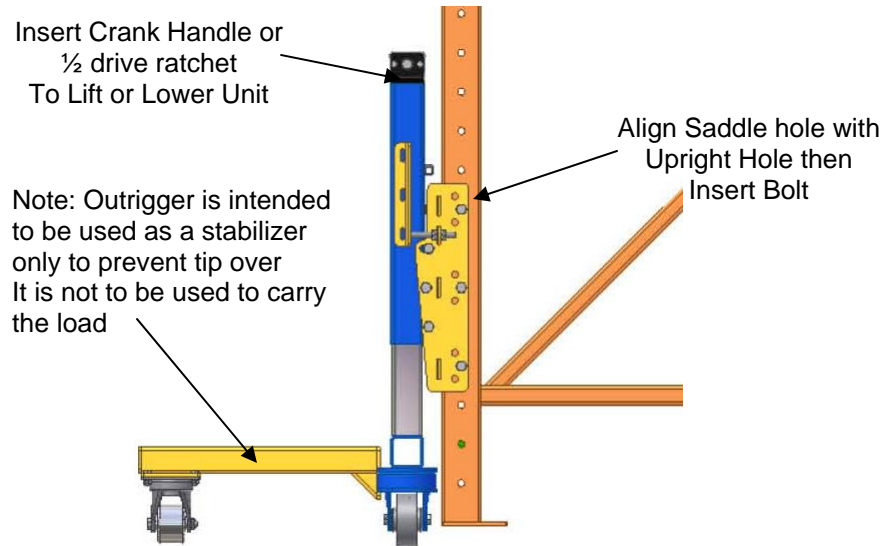

- J. Lifting the pallet rack
 1. This process requires that one person be appointed Team Leader and this person will be the one to give the commands to safely move the racking.
 2. The team should have a minimum of eight people total for the lift and move. (this may vary due to size and complexity of the move.)
 3. Two spotters will be required, one at each end of the run of racking. Their job is to keep the racking lifting straight up as the jacking process commences. They will call to the individuals that are cranking the lift jacks with the proper commands to insure that the units are lifted as perpendicular as possible. A level should be placed on each end upright in view of the spotter, enabling them to have a reference tool. They must also observe that no fixed object is contacted by the lifting of the racking. If they spot an inference items they must halt the Team lift immediately and have the team take corrective action.
 4. The cranking and thus lifting of the racking require a uniform lift of all components, The lift jacks have a cranking mechanism that has a one half inch square drive socket receiver, so that either a one half inch drive ratchet or speed wrench can be used. (this tool is not shipped with the unit.) The wrench can be used on either side of the

jack and as such you will not get “dead ended” against a wall. A team of people should start at one end of the row racking, with one person on each jack and start cranking. Each should turn the crank the same number of revolutions. As close as possible, at the same time. This is easily accomplished by one member of the team counting the turns of the crank by the number. Such as one and each member then completes one complete revolution of the crank, after four turns team #1 moves to the next upright and repeats the process. After team #1 moves to the third upright then team #2 should start at the first upright and crank the jacks four revolutions and follow the entire row to completion. Team #1 would move to starting end and repeat the process. This is done until the pallet racking is lifted clear of the floor anchors. The Team Leader is responsible for determining that all of the concrete anchors have been cleared prior to moving the racking. While the racking was being lifted the spotters should be carefully observing that the racking was being lifted perpendicular and not hanging up on any objects.

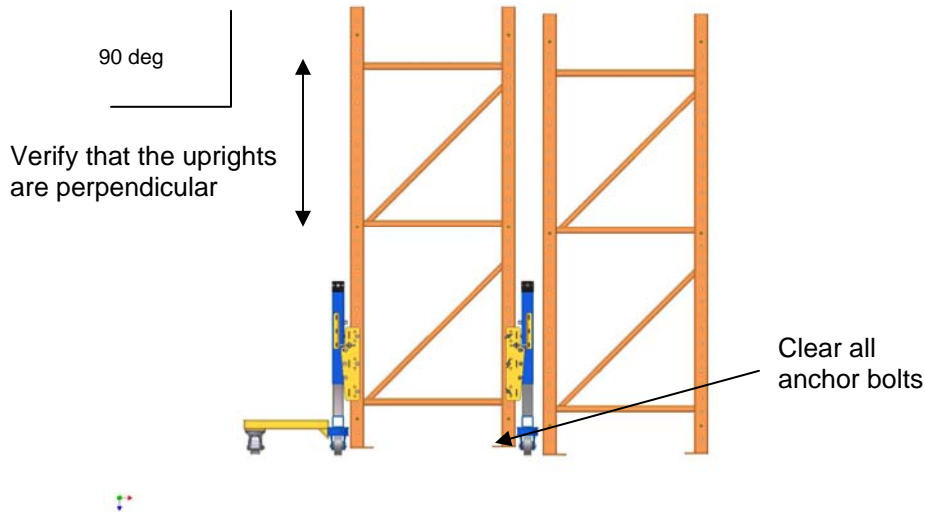

The Team leader should now re-inspect all phases of the lift and check the stability of the elevated racking. The route to the new rack location should be inspected to assure that the route is free of debris and stored items. A thorough inspection of the floor along the route is required to determine out of level conditions and deep cracks or holes in the floor. The chart shows the tilt of the racking off of the center mark as the Pallet Rack Lifter traverses the warehouse. The maximum curb differential will vary for each width of racking (48, 42 & 36). The 36" width will be the least tolerant of an extreme curb height differential.

Floor Differential		Off center tilt for the following rack widths in inches:		
		36	42	48
1/4	0.2500	1.333	1.143	1.000
3/8	0.3750	2.000	1.714	1.500
7/16	0.4375	2.333	2.000	1.750
1/2	0.5000	2.667	2.286	2.000
5/8	0.6250	3.333	2.857	2.500
3/4	0.7500	4.000	3.429	3.000
1	1.0000	5.333	4.571	4.000

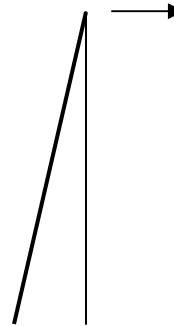

Note: These calculations are computed without the stabilizing outriggers in place. Using the outriggers will lessen the vertical tilt angles and make it more stable in moving.

It is my opinion that the thirty-six inch racking should not cross over a curb differential that exceeds 5/8 of an inch. The other factor is how the racking is loaded. Under no circumstances should the racking be moved over a curb height differential exceeding 3/4 of an inch without a ramp to bridge the lift and then it must not exceed one inch..

The Pallet Rack Lifter will tolerate a concave depression (or floor gap) between floor slabs of up to a 3/4 inch horizontal distance (castor wheel diameter is 4 inches).

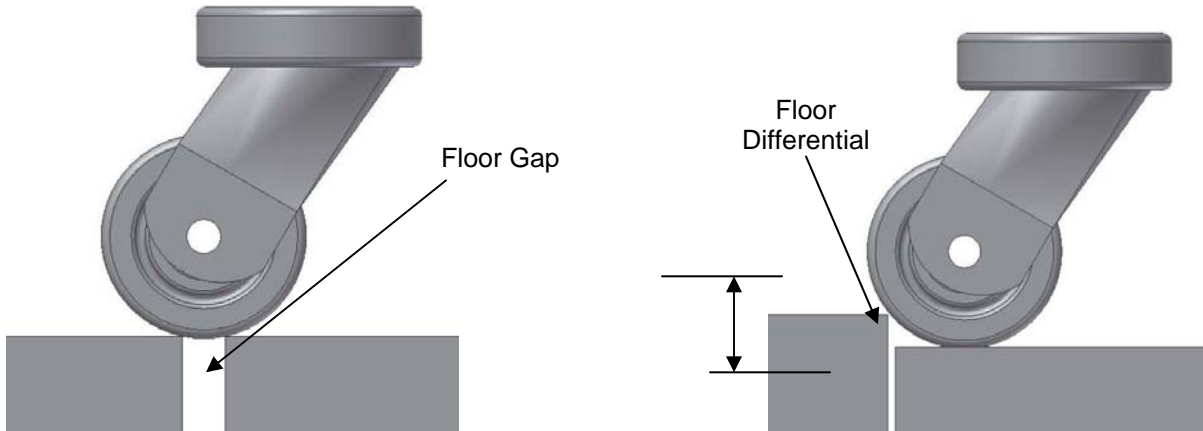

5. Moving the pallet racking should be done manually by placing workers at each of the uprights and then pushing. **Do not use a forklift**, as too much force can be applied and damage or injury could result.
6. Every attempt should be made to maintain a constant uniform speed to the new location. Do not get the load moving too fast – it is hard to stop and items may be vibrated off of the shelves.
7. Move the racking away from its original location being careful not to “hang it up” on any of the floor anchors. As soon as space permits install the outriggers on the rest of the Lift Jack assemblies prior to moving the racking to the new location.

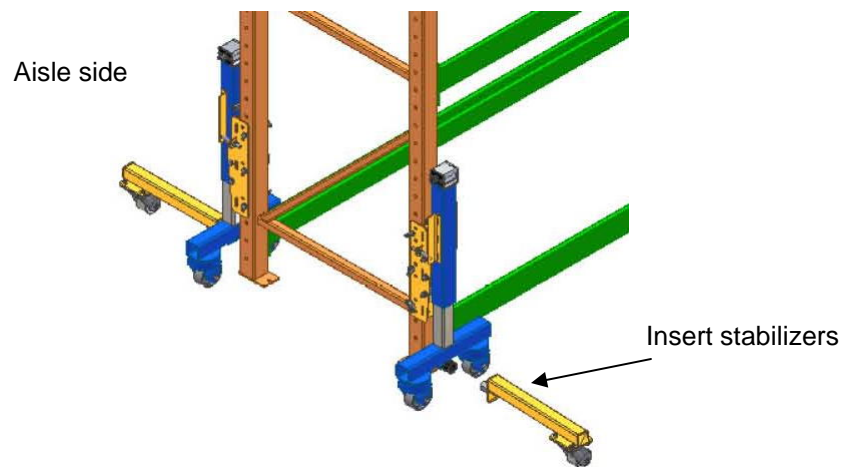

- a. After the pallet racking has been moved to the new location. (The targets for the uprights should have been already been marked out on the floor). Locate over targets and then to lower the units, reverse the lift sequence. The spotters should maintain their vigilance that the racking maintains its perpendicularity while being lowered.
- b. After the pallet racking run has been lowered into place remove all of the Lift Jack assemblies and move them back to the next run to be moved or store them in the cabinet if this is your last run.

Please note the safety and operating decals that are placed on the equipment.

As the designer and builder of this equipment I expect all people involved in the moving and resetting of the pallet racking to work safely and use good judgment. When this equipment is properly used it will save you countless hours of difficult work (the complete dismantling and then erecting of the racking again). As you use the equipment and gain skill in its application, you should come to appreciate the system as an excellent tool to help you perform your task. I always appreciate input from the field concerning what can be improved or what can be done to enhance the system. I have been involved in the design and manufacture of this type of equipment since 1984. Please visit our website for other products. www.gondolamovers.com

Thank you

Don Barber

Designer/inventor